

THOS. BAKER

Hedges Bar Table ASSEMBLY INSTRUCTIONS

PARTS REQUIRED

- A. Table Top – 1 pc.
- B. Table Legs – 4 pcs.
- C. Stretchers – 4 pcs.

HARDWARE INCLUDED: Hardware in “To Assemble” column is required to complete installation.

Hardware in the “Extra” column is in case you misplace or lose assembly hardware

To Assemble:

- D. Nut – 12 pcs.
- E. Lock Washer – 12 pcs.
- F. Flat Washer – 12 pcs.
- G. Headless Bolt – 12 pcs.
- H. Foot Glide – 4 pc.

Extra:

- I. Nut – 1 pcs.
- J. Lock Washer – 1 pcs.
- K. Flat Washer – 1 pcs.
- L. Headless Bolt – 1 pcs.
- M. Extra Foot Glide – 1 pc.

ASSEMBLY INSTRUCTIONS

HELPFUL HINT: Two people make this assembly much easier.

Table Base Assembly: Use hardware included in table base carton.

1. Screw the eight headless bolts (G) into the four legs of the table base (B) with the slotted end of the bolts facing outward, as illustrated. Tighten using a flat-head screwdriver.
2. Interlock two stretchers (C) and insert the bolts from one leg (B) through the interlocked stretchers (C), as illustrated in Figure 2. If the bolt holes from the interlocking stretchers do not line up properly, try mixing and matching various stretchers until the table can be properly assembled.
3. Attach one flat washer (F) and one lock washer (E) as shown, and then screw one nut (D) on to each bolt (G), as illustrated in Figure 2. Hand-tighten only.
4. Place the partially assembled table base on its side with one stretcher (C) pointed upward. Interlock a third stretcher with the stretcher pointed upward and insert the bolts (G) from a second leg (B) through the interlocked stretchers (C). Repeat Step 3. Hand-tighten only.
5. Repeat Step #4 for the remaining stretcher/leg.
6. Stand upright. Follow table top instructions to attach table top. Do not fully tighten all bolts until base has been attached to top.

Table Top Assembly: Use hardware included in table top package.

1. Invert the table top (A) and place on a padded, non-abrasive surface.
2. Screw the four headless bolts (G) into the four holes on the underside of the table top, with the slotted ends of the bolts facing upward. Tighten using a flat-head screwdriver.
3. Turn the assembled table base upside-down and place the base on top of the table top (A) bottom, inserting the table base holes into the bolts protruding from the top. See Figure 3.
4. Place a flat washer (F), locking washer (E), and a nut (D) on each bolt (G), as shown. See Figure 3. **Hand-tighten only.**
5. Tighten nuts (D) securing base legs (B) to stretchers (C) first, then tighten nuts (D) securing top (A) to base. To avoid stripping the screws, do not over-tighten or use electric drill.
6. Tighten all hardware on table base and top. With the help of another person, turn the table in the upright position. You are now ready to use your Bar Table. Enjoy.

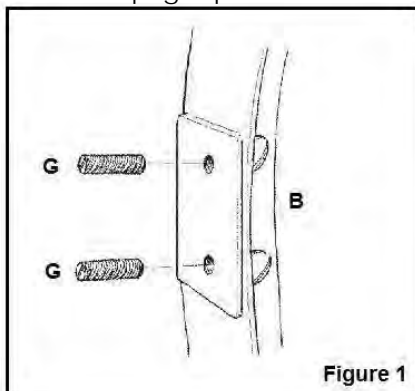

Figure 1

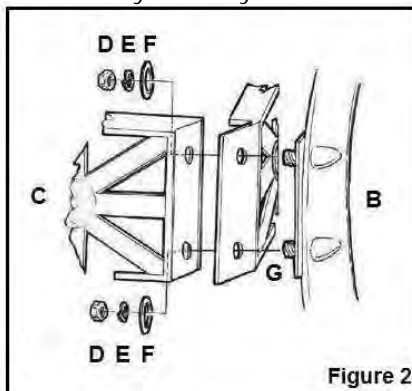

Figure 2

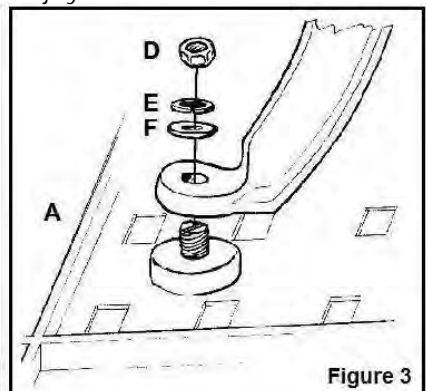

Figure 3

Do not use electric drill. Hand-tighten only.